

# Ball Valves

## Type 15080, Type 15081 - Ball Valve full bore



### Cryogenic-3-Piece-Ball Valve

Stainless steel body and topwork,  
 "live loaded" gland packing  
 "cleaned and degreased for oxygen service"  
 with upstream pressure relief hole  
 Marking acc. to EN 1626 and EN 12567

#### Part No. 15080.X.0020

Socket weld connection for stainless steel pipes acc. to ISO 1127

#### Part No. 15081.X.0020

Butt weld connection for stainless steel pipes acc. to ISO 1127

Available options - on request only:

- End connection for pipes acc. to ASTM A312 S10/S40
- Stainless steel lockable handle
- With pneumatic actuator
- ATEX Ex II 2GD



### Applications:

Approved for air gases, vapours and cryogenic liquefied gases.

Working temperature: -200°C / -328°F (73K) up to +200°C / +392°F (473K)

Materials	DIN EN	ASTM
1 Body	1.4409	A 351 CF3M
2 Ball seat	PTFE / Carbon filled (25%)	
3 Ball	1.4409	A 351 CF3M
4 Fitting	1.4404	A 276 Grade 316L
5 Flange	1.4306	A 276 Grade 304L
6 Stem	1.4404	A 276 Grade 316L
7 Elongation tube	1.4306	A 312 TP 304L
8 Gland packing up to DN50	33% C + 2% Gr PTFE	
8a Gland packing from DN65	PTFE	
9 Lever	1.1181	1035

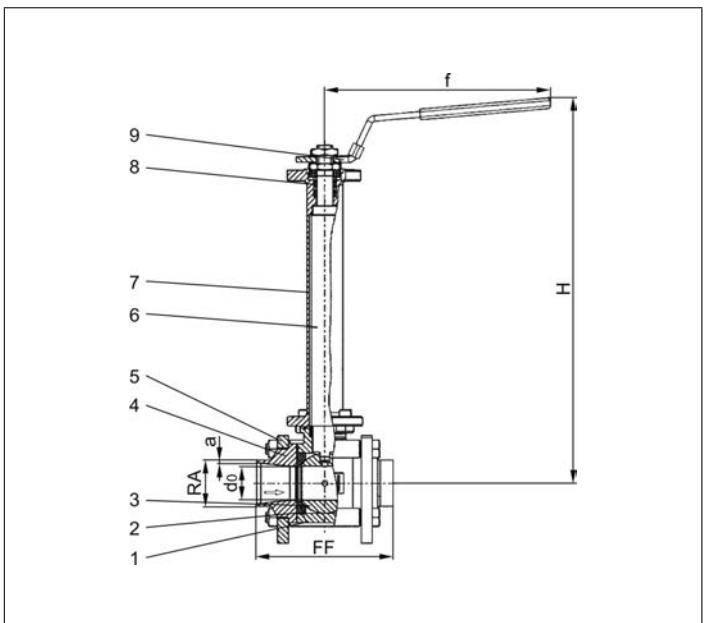

Standard marking acc. to Pressure Equipment Directive 97/23/EC (PED).



Type 15080, 15081	Technical data											
	DN	8	12	15	20	25	32	40	50	65	80	100
Nominal size	.X.	0813	1217	1521	2026	2533	3242	4048	5060	6576	8088	0114
Dimension code	PN	100	100	100	100	70	70	50	50	40	40	25
Nominal pressure	FF	65	65	70	85	100	110	125	150	180	210	230
Face-to-face dimension	H	225	225	230	276	280	321	326	346	426	438	471
Height	RA	13.5	17.2	21.3	26.9	33.7	42.4	48.3	60.3	76.1	88.9	114.3
Outside pipe-Ø ISO 1127	a	2.0	2.0	2.0	2.0	2.0	2.6	2.6	2.9	2.9	2.9	3.2
Wall thickness pipe ISO 1127	d <sub>0</sub>	11.1	11.1	14.0	19.0	25.0	32.0	38.0	50.0	64.0	76.0	100.0
Orifice	f	118	118	118	158	158	188	188	225	370	440	505
Length	ca. kg	1.05	1.05	1.45	2.35	3.05	4.55	6.30	11.10	20.15	32.22	45.00
Weight	m <sup>3</sup> /h	6.0	8.0	13.0	26.0	46.0	82.0	120.0	223.0	423.0	617.0	1154.0
Kvs-Value	gal/min	6.9	9.2	15.0	30.0	53.2	94.8	138.7	257.8	489.0	713.3	1334.0
Cv-Value												

Dimensions in mm.