

# Fire Safe and Offshore Valves

## Type 01843 - Actuated Globe Valve



Cryogenic-Globe Valves with Pneumatic Actuator, PN50 (DN100/150=PN40)  
 "Fire safe" type test approval acc. to EN ISO 10497 (only actuator spring closes)

Stainless steel body and topwork  
 Actuator - air opens, spring closes  
 "live loaded" gland packing  
 "cleaned and degreased for oxygen service" - the actuator is not cleaned and degreased for oxygen

**Part No. 01843.X.301\***

Butt weld connection for stainless steel pipes acc. to ISO 1127 or ASTM A312

**Part No. 01843.X.3014**

Socket weld connection for stainless steel pipes acc. to ISO 1127 or ASTM A312

Available accessories:

- Solenoid valve · Limit switch
- Electropneumatic positioner etc.

Available options - on request only:

- Welded stainless steel stubs acc. to ISO 1127 or ASTM A312 - length FF + 200mm
- Actuator "cleaned and degreased for oxygen service"



**Applications:**

Approved for air gases, vapours and cryogenic liquefied gases incl. LNG.  
 Working temperature: -255°C / -427°F (18K) up to +120°C / +248°F (393K)

Materials	DIN EN	ASTM
1 Body	1.4409	A 351 CF3M
2 Valve seal	PTFE / Carbon filled (25%)	
3 Disc	1.4404	A 276 Grade 316L
4 Bonnet gasket	Graphite	
5 Headpiece	1.4404	A 276 Grade 316L
6 Bolts	1.4571/A4	similar A 194 B8T
7 Elongation tube	1.4571	A 213 TP 316Ti
8 Stem	1.4404	A 276 Grade 316L
9 Gland packing	Graphite / PTFE / MICA	
10 Gland nut	1.4404	A 276 Grade 316L
11 Pillars	1.4404	A 276 Grade 316L
12 Bush	CW452K	B 159 UNS C51900

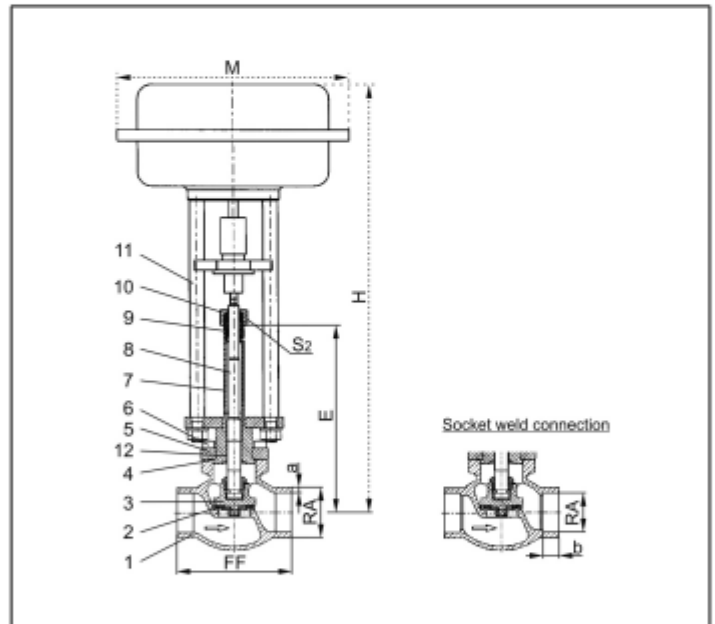

Standard marking acc. to Pressure Equipment Directive 97/23/EC (PED).



Type 01843 - Standard	Technical data														
	DN	10	15	15	20	25	32	40	40	50	65	80	100	150	
Nominal size	.X.	1012	1517	1521	2026	2533	3238	4042	4048	5060	657x	8088	0114	0168	
Dimension code	FF	70	85	85	100	115	115	130	130	155	205	245	280	400	
Face-to-face dimension	H	dependent on actuator													
Height	E	195	195	195	200	200	230	230	230	235	300	300	300	300	
Length	RA	12.0	17.2	21.3	26.9	33.7	38.0	42.4	48.3	60.3	76.1	88.9	114.3	168.3	
Outside pipe-Ø ISO 1127	a	1.0	1.6	2.0	2.0	2.0	2.0	2.0	2.0	2.0	2.6	3.2	6.0	7.1	
Wall thickness pipe ISO 1127	RA	13.72	17.15	21.34	26.67	33.40	-	42.16	48.26	60.33	73.03	88.90	114.3	168.3	
Outside pipe-Ø ASTM A312	a	dimensions acc. to S10 or S40													
Wall thickness pipe ASTM A312	b	6	10	10	13	13	-	13	13	16	16	16	20	20	
Socket depth	M	dependent on actuator													
Actuator-Ø	S <sub>2</sub>	30	30	30	30	30	36	36	36	36	36	36	41	41	
Wrench size across flats	ca. kg	1.9	2.15	2.2	2.4	3.1	3.8	6.5	6.5	9.0	15.2	20.0	28.0	60.9	
Weight w/o actuator	m <sup>3</sup> /h	1.6	3.8	4.3	6.7	11.5	14.0	20.6	22.6	37.1	71.1	104.0	170.0	350.0	
Kvs-Value	gal/min	1.9	4.4	5.0	7.8	13.4	16.2	23.9	26.3	43.2	82.7	120.9	195.2	401.8	
Cv-Value	mm	10	10	10	7	9	9	11	11	15	23	23	30	40	
Stroke															

Dimensions in mm. Compliance of tightness requirements acc. to EN 1626 for DN150 up to 20 bar differential pressure. In the range of >20-40 bar, 350-700ml (1 bar, 20°C [68°F]) are reached.

