

DN 65 à 150

Size 2"1/2 to 6"

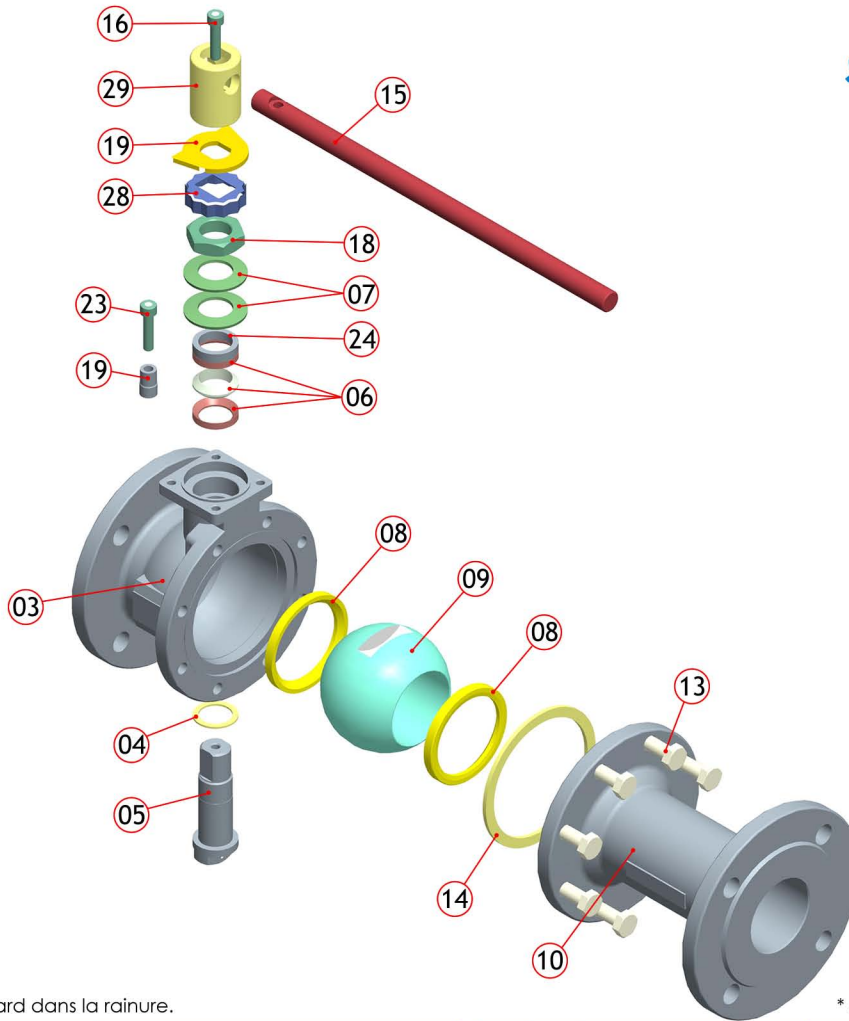

* Sphère perçée en standard dans la rainure.

* Drilled ball as standard in slot

N°	Nb	Description	Matière (EN)		Item	Qty	Description	Material (ASTM)	
			Inox	Acier				S.steel	C.steel
03	1	Corps monobloc ISO	1.4408	1.0619	03	1	Body	A351 CF 8 M	A216 WCB
04	1	Rondelle de friction	PTFE 20%PEEK	PTFE 20%PEEK	04	1	Stem thrust seal	20%PEEK PTFE	20%PEEK PTFE
05	1	Tige de manœuvre	1.4404	1.4404	05	1	Stem	316L	316L
06	1	Garniture de presse-étoupe			06	1	Gland packing		
		Version chimie	PTFE 33%C+2%Gr	PTFE 33%C+2%Gr			Chemical version	33%C+2%Gr PTFE	33%C+2%Gr PTFE
		Version Sécurité Feu	Graphite	Graphite			Fire-Safe version	Graphit	Graphit
07	2	Rondelles ressort	1.4310	1.4310	07	2	Spring washers	301	301
08	2	Sièges	PTFE	PTFE 20%PEEK	08	2	Seat	PTFE	20%PEEK PTFE
09*	1	Tournant sphérique			09*	1	Ball		
		DN65 à DN150	1.4409	1.4409			size 2"1/2 to 6"	CF3M (316L)	CF3M (316L)
10	1	Manchette de raccordement	1.4408	1.0619	10	1	Body connector	A351 CF 8 M	A216 WCB
13	8	Vis TH (DIN F1)			13	8	Screw (DIN F1)		
		DN65	1.4301	Classe 8.8 Zingué Bichromaté			Size 2"1/2	304	Class 8.8
	12	DN80 à DN150				12	Size 3" to 6"		
13b	8	Goujon (DIN F4)			13b	8	Stud (DIN F4)		
		DN65	1.4301	1.4301			Size 2"1/2	304	304
	12	DN80 à DN100				12	Size 3" to 4"		
14	1	Joint de corps			14	1	Body seal		
		Version chimie	PTFE	PTFE			Chemical version	PTFE	PTFE
		Version Sécurité Feu	1.4404 + Graphite	1.4404 + Graphite			Fire-Safe version	316L + Graphit	316L + Graphit
15	1	Levier standard	1.0037	1.0037	15	1	Handle standard	A283 Gr C	A283 Gr C
		Levier option	Voir paragraphe OPTION DE MANŒUVRE				Handle option	See OPTION FOR OPERATION	
16	1	Vis de levier	1.4301	1.4301	16	1	Handle screw	304	304
17	8	Écrous de serrage (DIN F4)			17	8	Nut screw (DIN F4)		
		DN65	1.4301	Classe 8.8 Zingué Bichromaté			Size 2"1/2	304	Class 8.8
	12	DN80 à DN100				12	Size 3" to 4"		
18	1	Écrou de fouloir	1.4404	1.4404	18	1	Nut gland	316L	316L
19	1	Plaque d'arrêt	1.4307	1.4307	19	1	Stop plate	304L	304L
19b	1	Bague de butée	1.4307	1.4307	19b	1	Locking plug	304L	304L
23	1	Vis Chc de butée	1.4301	1.4301	23	1	Screw stop	304	304
24	1	Foutoir	1.4404	1.4404	24	1	Gland	316L	316L
28	1	Frein d'écrou de P.E	1.4307	1.4307	28	1	Stop nut gland	304L	304L
29	1	Noix de manœuvre standard	1.0037	1.0037	29	1	Handle adaptor standard	A283 Gr C	A283 Gr C
		Noix de manœuvre option	1.4305	1.4305			Handle adaptor option	303	303

R2P

R2P: caractéristiques

Sièges 100% PEEK

Versions acier au carbone et inox CF8M

Version standard:

Perçage boule dans la rainure pour décompression du corps.
ATEX 94/9/CE

Option:

Perçage boule coté amont.

Agréments:

PED 97/23/CE
TA-Luft (Conformité aux émanations fugitives)
AD Merkblatt 2000
Matériau des sièges agréé FDA
Sur demande:
Marquage π suivant TPED 99/36/CE

R2P: technical data

100% PEEK seats

Carbon steel and stainless steel CF8M

Standard version:

Ball drilling in the stem mark for cavity relief
ATEX 94/9/CE

Option:

Upstream vent hole for cavity relief.

Approvals:

PED 97/23/CE
TA-Luft (fugitive emissions)
AD Merkblatt 2000
Seat material FDA approved
On request:
π marking according to TPED 99/36/CE

Courbes Pression-Température

R2P

Pressure-Temperature Diagrams

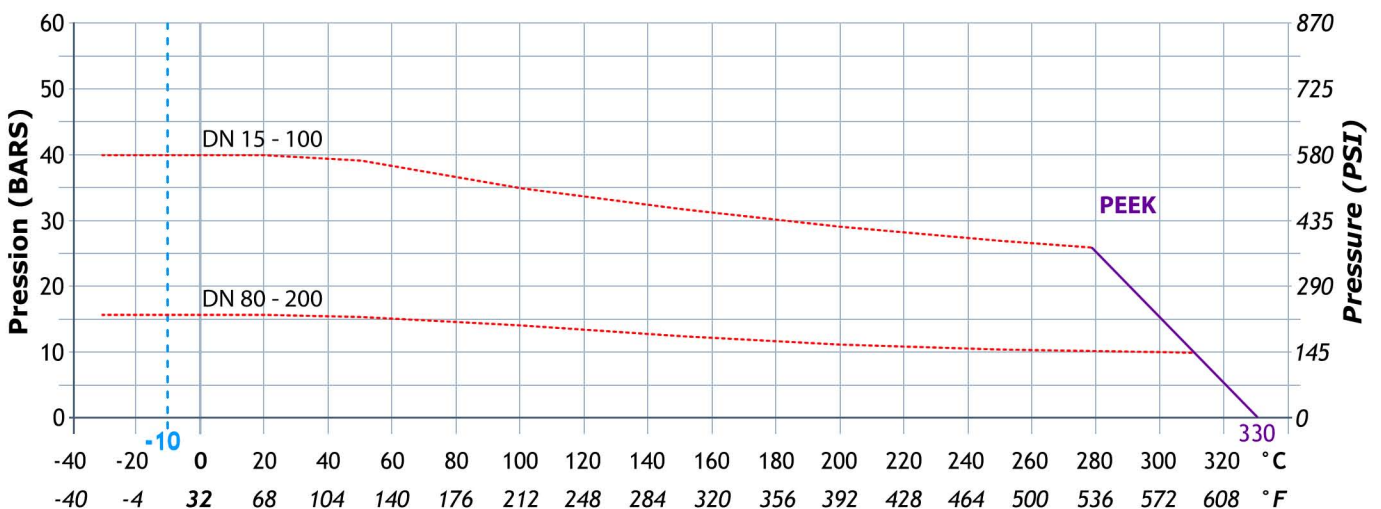

Température mini pour robinet en acier au carbone: **-10°C / 14°F**

Des solutions spécifiques sont disponibles pour les applications aux températures inférieures, veuillez nous consulter.

Minimum temperature for carbon steel ball valves: **-10°C / 14°F**

For lower temperature, customer-specific solutions are available on request. Please contact us for more information.

R2 DIN

R2 DIN court

DN 65 à 100
PN 16 / PN 40
DN 150
PN 16
Passage intégral

R2 DIN short pattern

Size 2"1/2 to 4"
PN 16 / PN 40
Size 6"
PN 16
Full bore

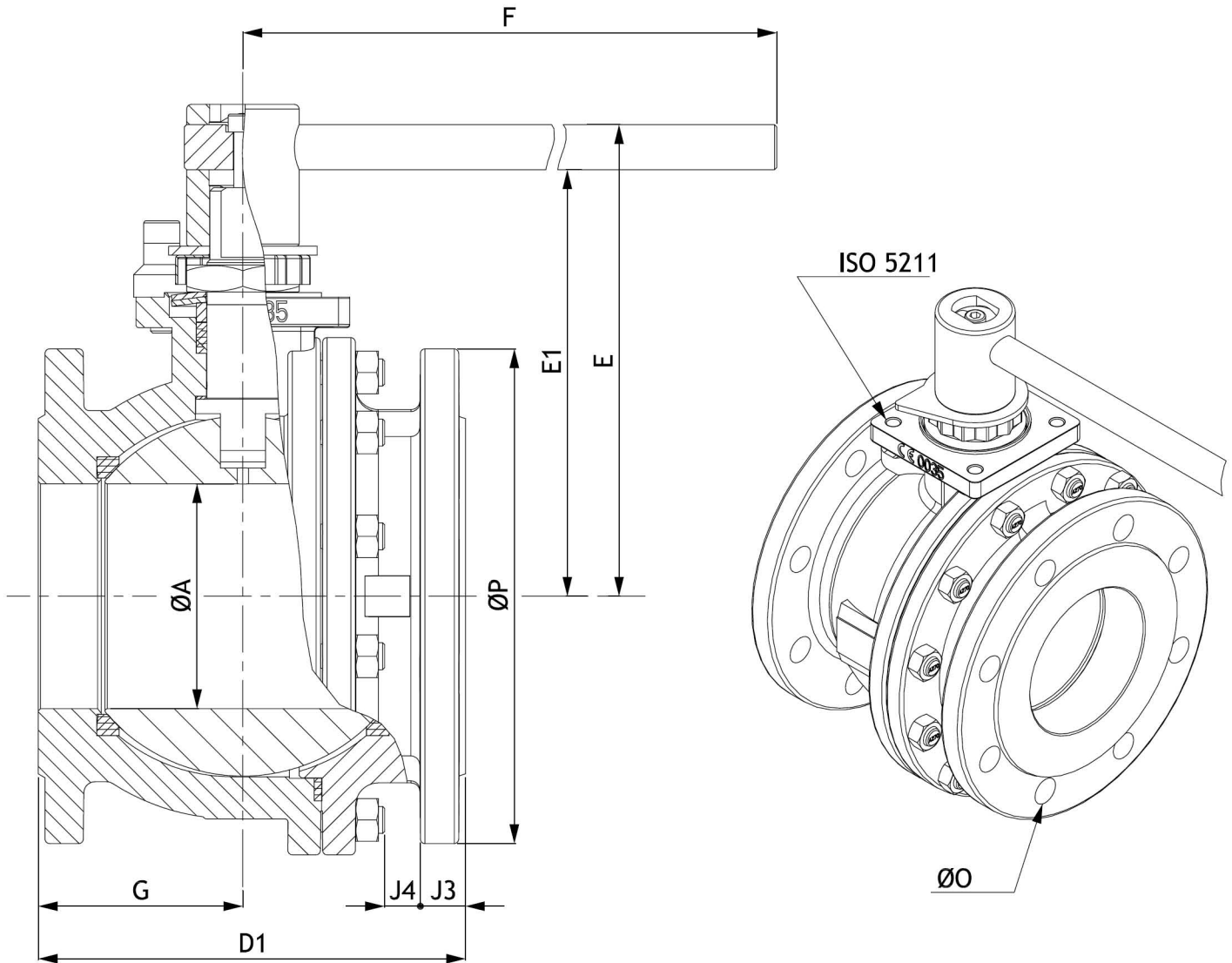

R2S

DN Size	PN	ØA	D1	E	E1	F	G	J3	J4	ØO	ØP	ISO 5211	Poids (Kg) Weight (Kg)	
65	2"1/2	40	64	170	173	155	370	67	24	21	8xØ18 / Ø145	185	F07	18,366
80	3"	40	76	180	183	165	370	76	24	21	8xØ18 / Ø160	200	F10	25,796
100	4"	40	100	190	210	190	505	81	24	19	8xØ22 / Ø190	235	F10	34,923
65	2"1/2	16	64	170	173	155	370	72	18	24	4xØ18 / Ø145	185	F07	16,750
80	3"	16	76	180	183	165	370	83	20	21	8xØ18 / Ø160	200	F10	24,850
100	4"	16	100	190	210	190	505	91	20	18	8xØ18 / Ø180	220	F10	31,450
150	6"	16	150	350	270	242	700	129	22	-	8xØ22 / Ø240	285	F12	75,000

Presse-étoupe

Gland-packing

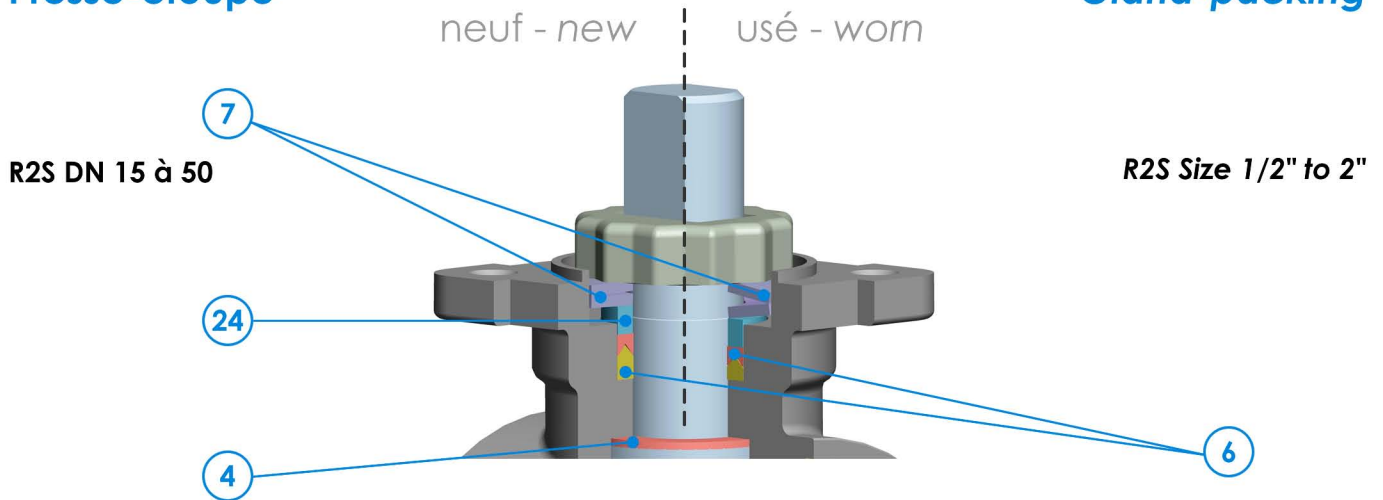

- Conception suivant NF EN 12516-1, DIN 3841, ANSI B16.34
- Antistatique suivant ISO 7121, NF EN 1983
Garniture (6) chargée PTFE+carbone+graphite
- Ensemble bille / ressort (B) entre tige & corps et tige & boisseau (DN > 50)
- Etanchéité primaire par rondelle de friction (4) en PTFE renforcé PEEK
- Etanchéité secondaire par garniture de type "chevron" (6) permettant de maintenir l'étanchéité lorsque la pression vient du corps du robinet
- Fouloir inox (24)
- Rattrapage du jeu de la garniture par rondelles ressort (7)

- Design according NF EN 12516-1, DIN 3841, ANSI B16.34
- Antistatic gland packing according to ISO 7121, NF EN 1983
Gland packing (6) in PTFE+carbon+graphite
- Ball / spring system (B) between stem & body and stem & ball (DN > 50)
- Primary sealing with thrust seal (4) in PEEK reinforced PTFE
- Secondary sealing with a "V-ring" packing (6) to allow sealing under pressure coming from the valve body
- Gland in stainless steel (24)
- Wear compensation thanks to the pair of spring washers (7)

