

Globe Valves

Type 1116 - Globe Valve



Cryogenic-Globe Valves, PN50

Stainless steel body and topwork,
 Inner parts made of stainless steel
 "live loaded" gland packing
 "cleaned and degreased for oxygen service"

Available options - on request only:

- Welded stainless steel stubs acc. to ISO 1127 or ASTM A312 - length FF + 200mm
- Extension H up to 900mm
- Valve with control disc (tapered design)
- Disc with PTFE/Carbon filled (25%) seal
- Further connection types



Applications:

Approved for air gases, vapours and cryogenic liquefied gases incl. LNG.
 Working temperature: -196°C / -321°F (77K) up to +120°C / +248°F (393K)
 Recommended working temperature (for versions without extension):
 -60°C / -76°F (213K) up to +120°C / +248°F (393K)

Materials	DIN EN	ASTM
1 Body	1.4308	A 351 CF8
2 Valve seal	PCTFE	
3 Disc	1.4301	A 479 Grade 304
4 Bonnet gasket	PTFE	
5 Headpiece	1.4308	A 351 CF8
6 Bolts	1.4301/A2	A 320 B8
7 Elongation tube	1.4541	A 213 TP 321
8 Stem	1.4301	A 479 Grade 304
9 Gland packing	Graphite / PTFE	
10 Gland nut	1.4305	A 276 Grade 303
11 Handwheel	Aluminium alloy	
12 Spring	1.4310	A 276 Grade 301
13 Bush	1.4541	A 479 Grade 321
14 Sleeve	1.4571	A 276 Grade 316Ti

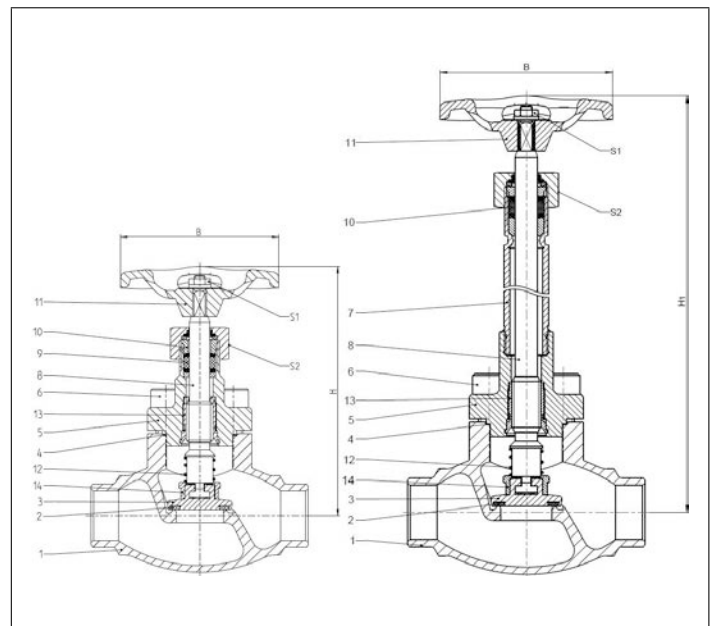

Standard marking acc. to Pressure Equipment Directive 2014/68/EU (PED).



Technical Data - standard design

Nominal size [DN]	Height (H) [mm]	Height (H ₁) [mm]	Handwheel-Ø (B) [mm]	Wrench size across flats (S ₁) [mm]	Wrench size across flats (S ₂) [mm]
10	140	270/370	100	10	27
15	140	270/370	100	10	27
20	140	270/370	100	10	27
25	140	270/370	100	10	27
40	175	270/370	125	13	32
50	200	270/370	125	13	32

Globe Valves

Type 1116 - Globe Valve



Connection types

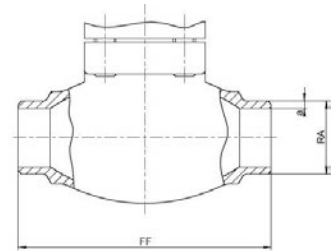

Butt weld connection acc. to

· ISO 1127

DN	Face-to-face dim. (FF) [mm]	Outside pipe-Ø (RA) [mm]	ISO Wall thickness pipe ISO (a) [mm]	Kvs-value [m ³ /h]	Cv-value [gal/min]	Weight, w.e.* [kg]	Part No.
10	70	13.5	2.3	1.6	1.9	0.85	1116.0135023.X0
15	85	17.2	1.6	3.8	4.4	0.96	1116.0172016.X0
15	85	21.3	2.0	4.3	5.0	0.98	1116.0213020.X0
20	100	26.9	2.0	6.7	7.8	1.43	1116.0269020.X0
25	115	33.7	2.6	11.5	13.4	1.92	1116.0337026.X0
40	130	42.4	2.6	20.6	23.9	3.49	1116.0424026.X0
40	130	48.3	2.6	22.6	26.3	3.36	1116.0483026.X0
50	155	60.3	2.6	37.1	43.2	4.94	1116.0603026.X0

Butt weld connection acc. to

· ASTM A312

DN	Face-to-face dim. (FF) [mm]	Outside pipe-Ø (RA) [mm]	ASTM Wall thickness pipe ASTM (a) [mm]	Kvs-value [m ³ /h]	Cv-value [gal/min]	Weight, w.e.* [kg]	Part No.
10	70	13.7	2.3	1.6	1.9	0.85	1116.0137S40.X0
15	85	17.1	1.6	3.8	4.4	0.96	1116.0171S10.X0
15	85	21.3	2.1	4.3	5.0	0.98	1116.0213S10.X0
20	100	26.6	2.1	6.7	7.8	1.43	1116.0266S10.X0
25	115	33.4	2.7	11.5	13.4	1.92	1116.0334S10.X0
40	130	42.4	2.7	20.6	23.9	3.49	1116.0424S10.X0
40	130	48.2	2.7	22.6	26.3	3.36	1116.0482S10.X0
50	155	60.3	2.7	37.1	43.2	4.94	1116.0603S10.X0

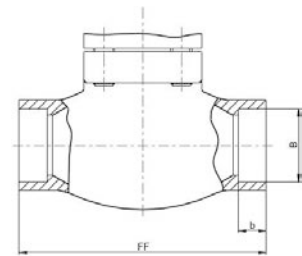

Socket weld connection acc. to

· ISO 1127

· ASTM A312

DN	Face-to-face dim. (FF) [mm]	Socket depth (b) [mm]	Socket diameter (B) [mm]	Kvs-value [m ³ /h]	Cv-value [gal/min]	Weight, w.e.* [kg]	Part No.
10	70	6.0	14.1	1.6	1.9	0.85	1116.0141000.X0
15	85	8.0	17.5	3.8	4.4	0.96	1116.0175000.X0
15	85	10.0	21.5	4.3	5.0	0.98	1116.0215000.X0
20	100	13.0	27.5	6.7	7.8	1.43	1116.0275000.X0
25	115	13.0	34.1	11.5	13.4	1.92	1116.0341000.X0
40	130	13.0	42.8	20.6	23.9	3.49	1116.0428000.X0
40	130	13.0	48.65	22.6	26.3	3.36	1116.0486000.X0
50	155	16.0	61.1	37.1	43.2	4.94	1116.0611000.X0

* w.e. = without extension

X = 0 (without extension), 1 (with 270mm extension), 2 (with 370mm extension)

Globe Valves

Type 1116 - Globe Valve



Connection types

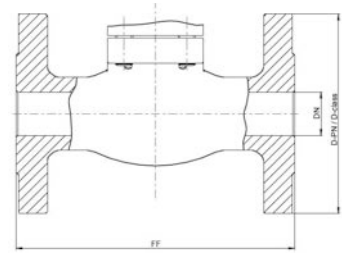

Flanged connection acc. to

- DIN EN 1092-1 PN40
- ANSI B16.5 class 300

DN / NPS	Face-to-face dim. (FF) [mm]	Flange-Ø (D-PN) [mm]	Flange-Ø (D-class) [mm]	Kvs-value [m ³ /h]	Cv-value [gal/min]	Weight, w.e.* [kg]	Part No. DIN EN	Part No. ANSI
15 / 1/2***	161	95	95	4.3	5.0	2.86	1116.015P040.X0	1116.015C300.X0
20 / 3/4***	181	105	115	6.7	7.8	3.72	1116.020P040.X0	1116.020C300.X0
25 / 1"	160	115	125	11.5	13.4	4.60	1116.025P040.X0	1116.025C300.X0
40 / 1-1/2"	200	150	155	22.6	26.3	8.62	1116.040P040.X0	1116.040C300.X0
50 / 2"	230	165	165	37.1	43.2	12.48	1116.050P040.X0	1116.050C300.X0

** welded version

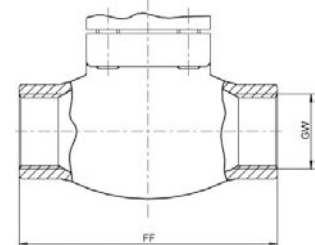

Female thread connection acc. to

- ISO 228/1 (G)
- NPT acc. to ANSI B 1.20.1 (NPT)

DN	Face-to-face dim. (FF) [mm]	Thread size (GW)	Kvs-value [m ³ /h]	Cv-value [gal/min]	Weight, w.e.* [kg]	Part No. G-thread	Part No. NPT-thread
10	70	1/4"	1.6	1.9	0.85	1116.FG02000.X0	1116.FN02000.X0
10	70	3/8"	2.2	2.6	0.85	1116.FG03000.X0	1116.FN03000.X0
15	85	1/2"	4.3	5.0	0.98	1116.FG04000.X0	1116.FN04000.X0
20	100	3/4"	6.7	7.8	1.43	1116.FG06000.X0	1116.FN06000.X0
25	115	1"	11.5	13.4	1.92	1116.FG10000.X0	1116.FN10000.X0
40	130	1-1/4"	20.6	23.9	3.49	1116.FG12000.X0	1116.FN12000.X0
40	130	1-1/2"	22.6	26.3	3.36	1116.FG14000.X0	1116.FN14000.X0
50	155	2"	37.1	43.2	4.94	1116.FG20000.X0	1116.FN20000.X0

Female thread connection acc. to

- ISO 7-1 (Rc or Rp)

DN	Face-to-face dim. (FF) [mm]	Thread size (GW)	Kvs-value [m ³ /h]	Cv-value [gal/min]	Weight, w.e.* [kg]	Part No. Rc-thread	Part No. Rp-thread
10	70	1/4"	1.6	1.9	0.85	1116.FR02000.X0	1116.FP02000.X0
10	70	3/8"	2.2	2.6	0.85	1116.FR03000.X0	1116.FP03000.X0
15	85	1/2"	4.3	5.0	0.98	1116.FR04000.X0	1116.FP04000.X0
20	100	3/4"	6.7	7.8	1.43	1116.FR06000.X0	1116.FP06000.X0
25	115	1"	11.5	13.4	1.92	1116.FR10000.X0	1116.FP10000.X0
40	130	1-1/4"	20.6	23.9	3.49	1116.FR12000.X0	1116.FP12000.X0
40	130	1-1/2"	22.6	26.3	3.36	1116.FR14000.X0	1116.FP14000.X0
50	155	2"	37.1	43.2	4.94	1116.FR20000.X0	1116.FP20000.X0

* w.e. = without extension

X = 0 (without extension), 1 (with 270mm extension), 2 (with 370mm extension)