

Safety Valves

Type 06216, Type 06217



Safety Valves, brass,
type tested TÜV-SV.1090 D/G

Standard safety valve
with FPM valve seal, open bonnet, with discharge holes
Inlet: male thread type G (BSPP) acc. to ISO 228/1

Part No. 06216.X.0000

Part No. 06217.X.0000

with lifting device

Available options - on request only:

- discharge holes with protection cap
- stainless steel spring - material 1.4571
- external parts nickel plated



Applications:

Provided as safety device for protection against excessive pressure in stationary and moveable gas cylinders and pressure vessels. Approved for air and similar gases.

Working temperature: -40°C / -40°F (233K) up to +200°C / +392°F (473K), suitable for horizontal installation

Materials	DIN EN	ASME/ASTM
1 Body	CW617N	B 283 UNS C37700
2 Valve seal	FPM (Viton-GLT)	
3 Disc	CW614N	B 455 UNS C38500
4 Stem	CW614N	B 455 UNS C38500
5 Bonnet	CW614N	B 455 UNS C38500
6 Spring	1.1200	A 227
7 Stem guide	PTFE	
8 Cap	CW614N	B 455 UNS C38500
9 Lifting device	CW614N	B 455 UNS C38500
10 Closing cap	CW507L	B 36 UNS C26800

Essential: Valves are delivered at a set pressure, therefore when ordering please confirm set pressure, medium and temperature.

Standard marking acc. to Pressure Equipment Directive 97/23/EC (PED).



Marking acc. to ASME Code Section VIII.

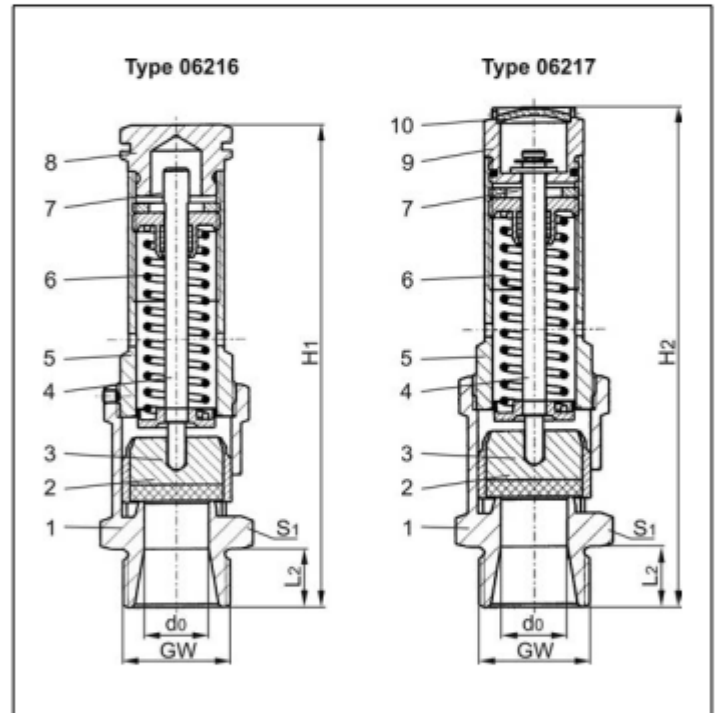

Type 06216, Type 06217	Technical data						
Nominal size	GW	1/2	3/4	1	1-1/4	1-1/2	2
Orifice	d ₀	12	15	20	25	32	40
Dimension code	.X.	0400	0600	1000	1200	1400	2000
Set pressure range	bar	0.2-25	0.2-30	0.2-30	0.2-22	0.2-16	0.2-12
Height	H ₁	103	122	149	169	198	224
Height	H ₂	107	126	150	172	200	228
Length	L ₂	14	16	18	20	22	25
Wrench size across flats	S ₁	27	32	41	50	55	70
Weight	ca. kg	0.25	0.41	0.72	1.23	1.73	3.09
Coeff. of discharge from 3.0 bar	α _w	0.83	0.83	0.73	0.71	0.69	0.66

Dimensions in mm.