

# Fire Safe and Offshore Valves

## Type 01853 - Actuated Trailervalue



**Cryogenic-Globe Valves with Pneumatic Actuator, PN50**  
 "Fire safe" type test approval acc. to EN ISO 10497

air pressure for operation 6,0 bar g (maximum 10.0 bar g)  
 Stainless steel body and topwork,  
 Actuator - air opens, spring closes  
 "live loaded" gland packing  
 "cleaned and degreased for oxygen service" - the actuator is not cleaned and degreased for oxygen  
 maximum working pressure of the valve depending on nominal size

**Part No. 01853.X.T0\*\***

\* Butt weld connection for stainless steel pipes acc. to ISO 1127 or ASTM A312

**Part No. 01853.X.T0\*4**

Socket weld connection for stainless steel pipes acc. to ISO 1127 or ASTM A312

Available options - on request only:

· Welded stainless steel stubs acc. to ISO 1127 or ASTM A312 - length FF + 200mm

### Applications:

Approved for air gases, vapours and cryogenic liquefied gases incl. LNG.

Working temperature: -255°C / -427°F (18K) up to +120°C / +248°F (393K)



Materials	DIN EN	ASTM
1 Body	1.4409	A 351 CF3M
2 Valve seal	PTFE / Carbon filled (25%)	
3 Disc	1.4404	A 276 Grade 316L
4 Bonnet gasket	Graphite	
5 Headpiece	1.4404	A 276 Grade 316L
6 Bolts	1.4571/A4	similar A 194
7 Elongation tube	1.4571	A 213 TP 316Ti
8 Stem	1.4404	A 276 Grade 316L
9 Spring	1.4571	A 313 Grade 316Ti
10 Flange	1.4404	A 276 Grade 316L
11 Headpiece	1.4404	A 276 Grade 316L
12 Gland packing	Graphite / PTFE / MICA	
13 Gland nut	1.4571	A 313 Grade 316Ti
14 Pillars	1.4404	A 276 Grade 316L
15 Bush	CW452K	B 159 UNS C51900
16 Actuator	Rubber	

Standard marking acc. to Pressure Equipment Directive 97/23/EC (PED).

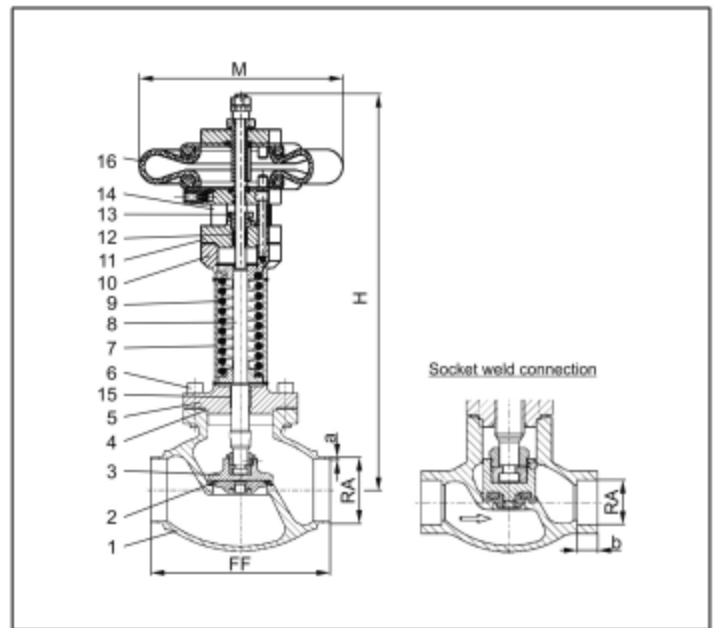

Type 01853	Technical data							
	DN	15	25	40	40	50	65	80
Nominal size	.X.	1521	2533	4042	4048	5060	657x	8088
Dimension code	FF	85	115	130	130	155	205	245
Face-to-face dimension	H	395	444	400	400	440	470	500
Height	RA	21.3	33.7	42.4	48.3	60.3	76.1	88.9
Outside pipe-Ø ISO 1127	a	2.0	2.0	2.0	2.0	2.0	2.6	3.2
Wall thickness pipe ISO 1127	RA	21.34	33.40	42.16	48.26	60.33	73.03	88.90
Outside pipe-Ø ASTM A312	a	dimensions acc. to S10 or S40						
Wall thickness pipe ASTM A312	b	10	13	13	13	16	16	16
Socket depth	M	229	229	229	229	229	229	229
Actuator-Ø	ca. kg	7.2	9.1	10.5	10.5	14.5	17.4	22.5
Weight	m <sup>3</sup> /h	4.3	11.5	22.6	22.6	37.1	71.1	104.0
Kvs-Value	gal/min	5.0	13.4	23.9	26.3	43.2	82.7	120.9
Cv-Value	mm	10	9	11	11	15	23	23
Stroke								

Dimensions in mm.