

Actuated Valves

Type 02413 - Actuated Globe Valve



Cryogenic-Globe Valves with Pneumatic Actuator, PN50

Bronze body and stainless steel topwork, inner parts in brass

Actuator - air opens, spring closes or contrary

"live loaded" gland packing

"cleaned and degreased for oxygen service" - the actuator is not cleaned and degreased for oxygen

Part No. 02413.X.*011

Male thread for union connection

Available accessories:

- Solenoid valve
- Limit switch
- Electropneumatic positioner etc.

Available options - on request only:

- Socket end for stainless steel pipes acc. to ISO 1127
- Actuator "cleaned and degreased for oxygen service"
- Electric actuator
- Valve with check disc

Applications:

Approved for air gases, vapours and cryogenic liquefied gases incl. LNG.

Working temperature: -196°C / -321°F (77K) up to +120°C / +248°F (393K)



Materials	DIN EN	ASTM
1 Body	CC491K	B 62 UNS C83600
2 Valve seal	PTFE / Carbon filled (25%)	
3 Disc	CW614N	B 283 UNS C38500
4 Bonnet gasket	PTFE	
5 Headpiece	1.4301	A 276 Grade 304
6 Bolts	1.4301/A2	A 194 B8
7 Elongation tube	1.4541	A 213 TP 321
8 Stem	1.4301	A 276 Grade 304
9 Gland packing	Graphite / PTFE	
10 Gland nut	CW614N	B 283 UNS C38500
11 Pillars	1.4404	A 276 Grade 316L
12 Bush	CW452K	B 159 UNS C51900

Standard marking acc. to Pressure Equipment Directive 97/23/EC (PED).

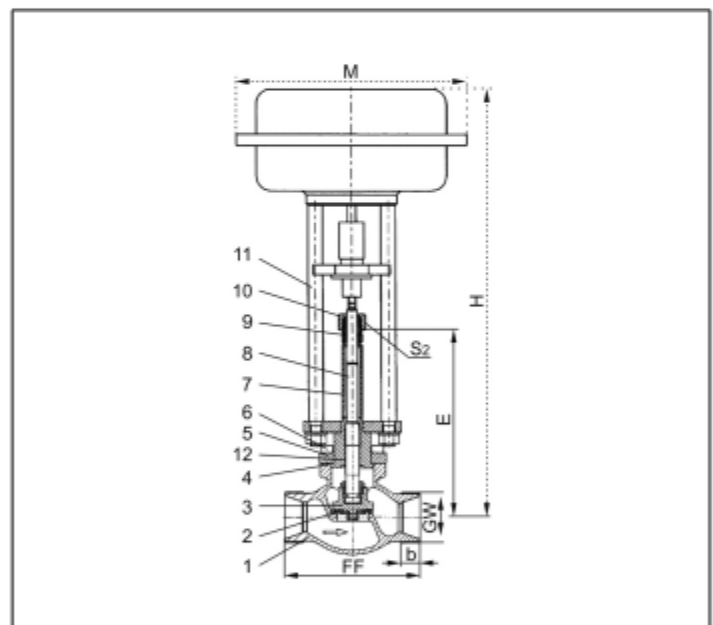

Type 02413 - Standard design	Technical data					
Nominal size	DN	10	20	32	40	50
Dimension code	.X.	0100	0200	0320	0400	0500
Face-to-face dimension	FF	60	85	115	140	160
Union thread	GW	M26x1.5	M40x2.0	M55x2.0	M65x2.0	M78x2.0
Height	H	dependent on actuator				
Length	E	195	200	230	230	235
Thread length	b	10	11	14	17	20
Actuator-Ø	M	dependent on actuator				
Wrench size across flats	S ₂	30	30	36	36	36
Weight w/o actuator	ca. kg	1.6	2.7	4.3	6.2	9.2
Kvs-Value	m ³ /h	2.2	6.7	12.1	22.6	37.1
Cv-Value	gal/min	2.6	7.8	14.1	26.3	43.2

Dimensions in mm.