

Fire Safe Valves

Type 15090, Type 15091 - Ball Valve full bore



Cryogenic-3-Piece-Ball Valve

"Fire safe" type test approval acc. to EN ISO 10497

Stainless steel body and topwork,

"live loaded" gland packing

"cleaned and degreased for oxygen service"

with upstream pressure relief hole

Marking acc. to EN 1626, EN 12567, ISO 10497 and ATEX Ex II 2GD

Part No. 15090.X.002*

Socket weld connection for stainless steel pipes acc. to ISO 1127

Part No. 15091.X.002*

Butt weld connection for stainless steel pipes acc. to ISO 1127

Available options - on request only:

- End connection for pipes acc. to ASTM A312 S10/S40
- Stainless steel lockable handle
- With pneumatic actuator



Applications:

Approved for air gases, vapours and cryogenic liquefied gases.

Working temperature: -200°C / -328°F (73K) up to +200°C / +392°F (473K)

Materials	DIN EN	ASTM
1 Body	1.4409	A 351 CF3M
2 Ball seat	PTFE / Carbon filled (25%)	
3 Ball	1.4409	A 351 CF3M
4 Fitting	1.4404	A 276 Grade 316L
5 Flange	1.4306	A 276 Grade 304L
6 Stem	1.4404	A 276 Grade 316L
7 Elongation tube up to DN50	1.4307	304L
7a Elongation tube from 1.4404 DN65	A 276 Grade 316L	
8 Gland packing	Graphite	
9 Lever	1.1181	1035
10 Seal	Graphite	

Standard marking acc. to Pressure Equipment Directive 97/23/EC (PED).

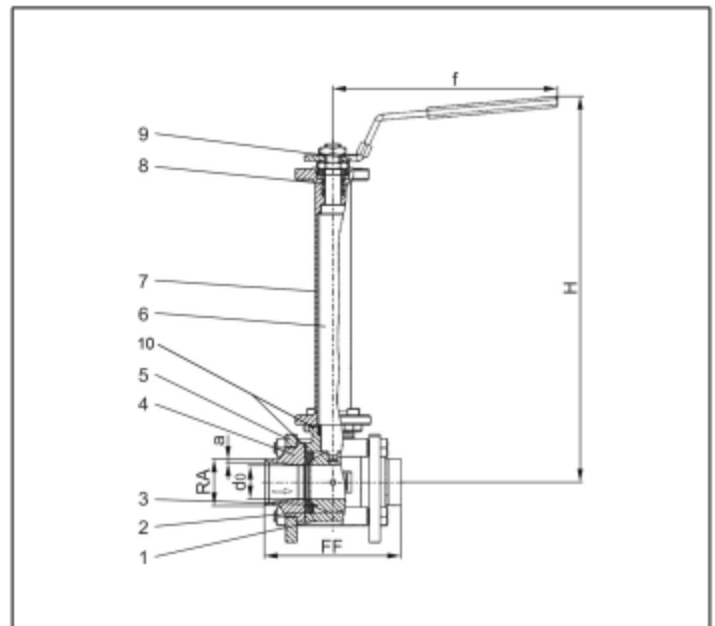

Type 15090, 15091	Technical data											
	DN	8	12	15	20	25	32	40	50	65	80	100
Nominal size	DN	8	12	15	20	25	32	40	50	65	80	100
Dimension code	.X.	0813	1217	1521	2026	2533	3242	4048	5060	6576	8088	0114
Nominal pressure	PN	100	100	100	100	70	70	50	50	40	40	25
Face-to-face dimension	FF	65	65	70	85	100	110	125	150	180	210	230
Height	H	225	225	230	276	280	321	326	346	426	438	471
Outside pipe-Ø ISO 1127	RA	13.5	17.2	21.3	26.9	33.7	42.4	48.3	60.3	76.1	88.9	114.3
Wall thickness pipe ISO 1127	a	2.0	2.0	2.0	2.0	2.0	2.6	2.6	2.9	2.9	2.9	3.2
Orifice	d ₀	11.1	11.1	14.0	19.0	25.0	32.0	38.0	50.0	64.0	76.0	100.0
Length	f	118	118	118	158	158	188	188	225	370	440	505
Weight	ca. kg	1.05	1.05	1.45	2.35	3.05	4.55	6.30	11.10	20.15	32.22	45.00
Kvs-Value	m ³ /h	6.0	8.0	13.0	26.0	46.0	82.0	120.0	223.0	423.0	617.0	1154.0
Cv-Value	gal/min	6.9	9.2	15.0	30.0	53.2	94.8	138.7	257.8	489.0	713.3	1334.0

Dimensions in mm.

