

Single-stage, for reactive, toxic, oxidizing and corrosive (option Hastelloy internals) gas and gas mixtures, purity max. 6.0, inlet pressure 230 bar/ 3300 psi, outlet pressure range 0,5 - 50 bar / 7 - 725 psi

Highlights

- ▲ With external gas purging device
- ▲ Inlet and outlet shut-off valve

Features

This gas panel reduces the cylinder pressure of 230 bar to outlet pressure values ranging from 1 to 14 bar or 2.5 to 50 bar (option 10 to 230 bar). The SMD 500-27 is mounted on a stainless steel panel and consists of a pressure regulator, inlet and outlet pressure gauges, a relief valve and inlet and outlet shut-off valves for the purge and the process gas. A choice of stainless steel coils or flexible high pressure hoses is available for the connection to the gas cylinder. The use of contact pressure gauges (accessories) facilitates monitoring of the gas reserves.

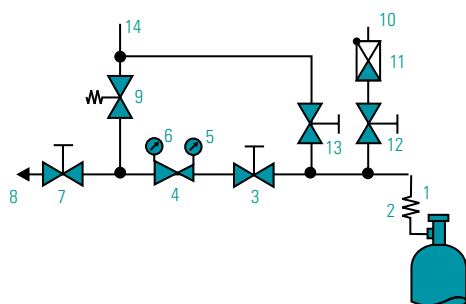

- 1 Cylinder connection
- 2 Connection spiral
- 3 Process gas inlet shut-off valve
- 4 Pressure regulator - single-stage
- 5 Inlet pressure gauge
- 6 Outlet pressure gauge
- 7 Process gas outlet shut-off valve
- 8 Process gas outlet
- 9 Relief valve
- 10 Purge gas inlet
- 11 Non-return valve
- 12 Purge gas inlet valve
- 13 Purge gas outlet valve
- 14 Purge gas outlet

Application

Gas supply panels are installed in the gas centre (cylinder stock room or gas cabinet). They reduce the cylinder pressure to the line pressure. Via the subsequent piping system the gas will be guided to the point of use.

This design with external gas purging offers the following advantages:

1. Purging the gas rest remaining in the system before cylinder changing improves the personal safety level.
2. Maintaining gas purity by purging the atmospheric air which has penetrated the system after cylinder changing.
3. Purging with dry inert gas reduces humidity and extends the expected live span when corrosive gases are used.

Technical data

Body material:	stainless steel 316L (1.4404) specially cleaned and electro-polished
Relief valve:	10 - 200 bar version without
Body sealings:	PCTFE
Relief valve seat material	FKM, (EPDM, FFKM) on request
Performance data:	see chapter 5.1
Basic design aspects:	see page 10
Pressure gauge range:	-1 - 10 bar (-15 - 145 psi) 0 - 25 bar (0 - 365 psi) 0 - 40 bar (0 - 600 psi) 0 - 80 bar (0 - 1150 psi) 0 - 315 bar (0 - 4500 psi)
Weight:	1,1 kg
Dimensions (wxhxd):	ca. 305 x 235 x 185 mm
Pressure gauge range:	-1 - 18, 0 - 80, (optional 0 - 315) bar -14,5 - 261, 0 - 1161, (optional 0 - 4572) psi
Purge inlet:	tube fitting 6 mm with integrated check valve
Purge outlet:	tube fitting 6 mm
Inlet:	M 14 x 1,5 (standard) NPT 1/4" f (optional)

Order code

Type	Material	Inlet pressure	Outlet pressure	Inlet conn.	Outlet conn.	Contact pressure gauge	Gas type
SMD 500-27	SS	F	6	N14	CL6 SS	Ki	Gas
SMD 500-27	SS = stainless steel	F = 230 bar/3300 psi	6 = 0,5 - 6 bar/ 7 - 85 psi 14 = 1 - 14 bar/ 15 - 200 psi 50 = 2,5 - 50 bar/ 35 - 720 psi	N14 = NPT 1/4"	0 CL6 CL8 CL10 CL12 SS = stainless steel	0 = without Ki = with	Specification of used gas

For proper installation and service of this panel a gas specific spiral connection tube is necessary. See in chapter Accessory page 94.

Outlet: (expl.: CL6=tube fitting with outer diameter 6 mm, 0 = without).